

CNC CIRCULAR SAWING MACHINE

The most reliable way of increase productivity and quality!

- High Productivity
- Excellent quality of workpiece
- High rigid structure



CNC Circular Sawing Machine

Applications

This machine has been designed for various kinds of workpieces in the industries like below.

상림엔스피가 생산하는 KKATO CNC CIRCULAR SAWING MACHINE으로 다양한 분야의 제품을 최고의 품질로 가공할 수 있습니다.

Round Bar
환봉

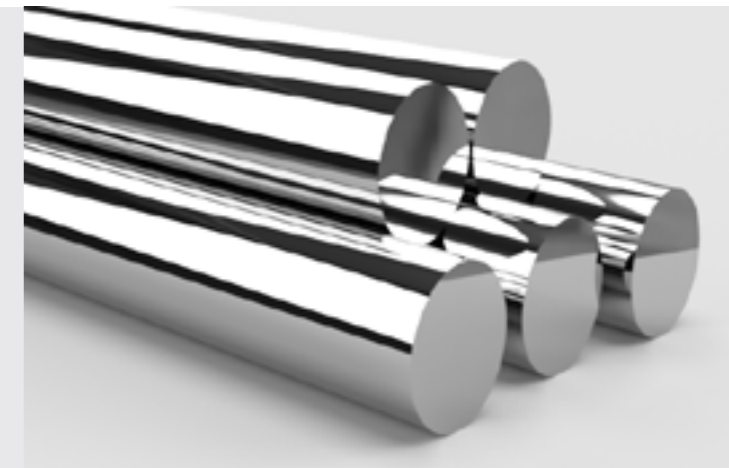

Square Bar
각재

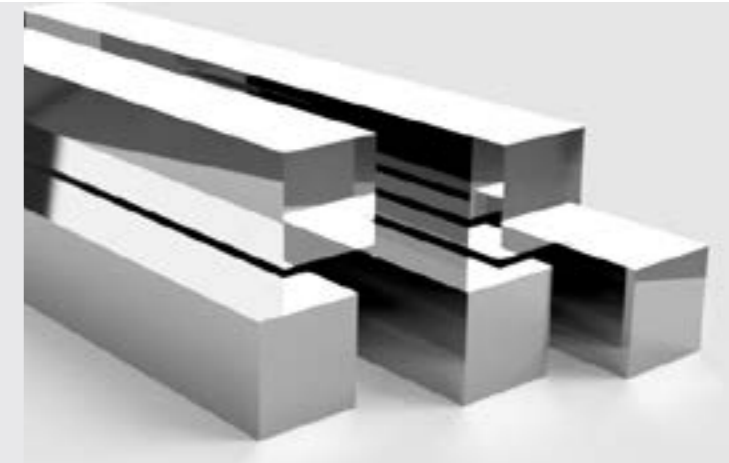

Pipe
파이프



CNC Circular Sawing Machine

KKATO CNC CIRCULAR SAWING MACHINE

KKATO CNC CIRCULAR SAWING MACHINE is a high-performance sawing machine with high productivity, high rigidity, and high durability required by customers.

- High productivity
- High rigidity body with casting structure design
- Equipment with high durability using only reliable parts
- high quality cut cross section
- With strong cutting power, even difficult-to-cut materials can be cut without difficulty
- Can cut general and special steels such as SUS, SS45C, Inconel, etc.

KKATO CNC CIRCULAR SAWING MACHINE 은 고객이 요구하는 고생산성, 고강성, 고내구성을 가진 고성능 톱기계입니다.

- 높은 생산성
- 주물 구조 설계로 고강성의 BODY
- 신뢰성 있는 부품만을 사용하여 고내구성을 가진 장비
- 높은 품질의 절단 단면
- 강력한 절단력으로 난삭재 또한 어려움 없이 절단가능
- SUS, SS45C, 인코넬 등 일반강 및 특수강 절단가능

+ High-performance powder brake
고성능 파우더 브레이크



+ Interlocked spindle brush
스핀들 연동 브러쉬



+ Operator panel
운전자 조작반 (한글지원)



+ High-ridged vise
고강성, 고내구성 바이스



+ Precise feeding system
고정밀 이송 시스템



Specification

Model	Unit	SN70NC	SN130NC	SN160NC
Cutting range	mm	Ø10 ~ Ø75	Ø40 ~ 135	Ø75 ~ 160
Cutting length	mm	10 ~ 3,000	10 ~ 3,000	15 ~ 3,000
Blade size	mm	Ø285 × Ø32 × t2.0	Ø420 × Ø50 × t2.7	Ø480 × Ø50 × t2.8
Number of teeth	Z	60, 80	50, 60, 80	50, 60
Motor power	kW	7.5	15	15
Speed	min ⁻¹	70 ~ 200	50 ~ 120	32 ~ 115
Structure		Servo motor / 45 Slant bed	Servo motor / 45 Slant bed	Servo motor / 45 Slant bed
Cutting feed	mm/min	0 ~ 3,000	0 ~ 3,000	0 ~ 3,000
Rapid cutting feed	m/min	20	20	12
Trim cut length	mm	10 ~ 99	10 ~ 99	15 ~ 99
Min. remnant	mm	60 + cutting length	83 + cutting length	90 + cutting length
Clamp method		H & V vise	H & V vise	H & V vise
Required electric power	kW	13	25	26
Machine weight	kg	3,500	6,000	6,200
*Required space	mm	L2,700 × W1,900 × H1,800	L3,000 × W2,200 × H2,100	L3,100 × W2,200 × H2,150
Max. Bar rod Ø'ty		Ø75 × 6m × 10ea	Ø135 × 6m × 8ea	Ø160 × 6m × 6ea
Supply bar length	m	3 ~ 6	3 ~ 6	3 ~ 6

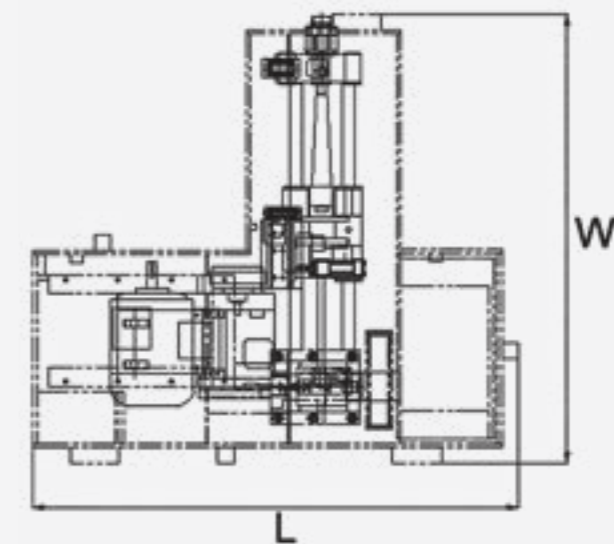
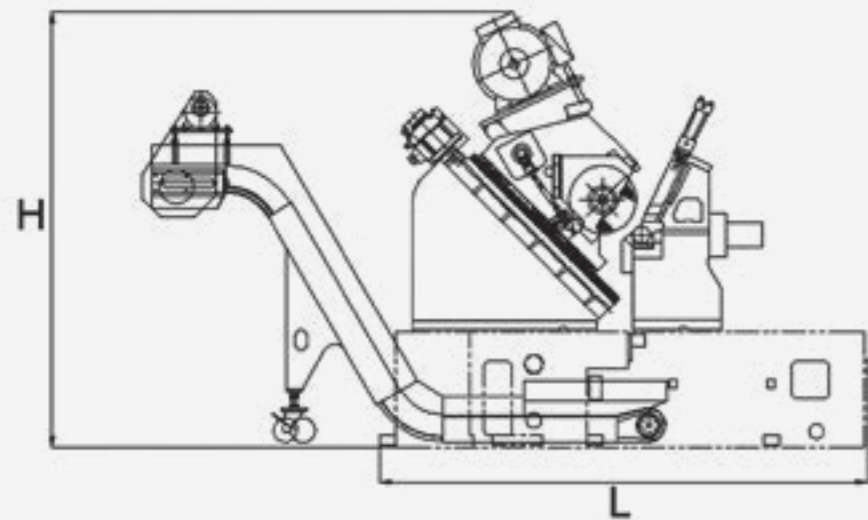



QR 코드를 스캔해보세요
Scan QR code and visit our website.
www.sangnim.com



Head Office and Factory 본사 및 공장 :
경상남도 창원시 성산구 성산패총로32
32, Seongsanpaechong-ro, Seongsan-gu, Changwon-si,
Gyeongsangnam-do, Republic of Korea
TEL : +82 55-287-1534
FAX : +82 55-287-1535
E-mail : sangnim@sangnim.com



Shanghai office 上海悦农贸易有限公司 :
17-201 Room, No. 595, Yongtai Road, Shanghai, China (PC -200123)
Mobile: 0086-15921634117
E-mail: marineofchina@163.com

